



- Black box system
- Automatic calculation of the purge time
- WEB interface
- 3 x PT100/1000 inputs
- Modular design
- Separate purge gas input and output

Explosion protection

ATEX marking	Ⓜ II 3G Ex ec mc ic [ic pzc] IIC T4 Gb Ⓜ II 3D Ex tc [ic pzc] III C T130 °C Db
Certification	BVS 19 ATEX E 016
IECEx marking	Ex ec mc ic [ic pzc] IIC T4 Gb
Certification	Ex tc [ic pzc] III C T130 °C Db IECEx BVS 19.0038X
Other approvals and certificates, see www.bartec.com	
Ambient temperature	In storage -20 °C to +60 °C During operation -25 °C to +60 °C/T4 -25 °C to +50 °C/T5

Technical data

Directives	Directive 2014/30/EU Directive 2014/34/EU
Structure	Ex e protective housing with integrated Ex mc/ic-protected p control system
Housing material	V4A stainless steel
IP rating	IP 66 according to EN/IEC 60529 IP 64 according to EN/IEC 60079-0
Terminals	Ex e: 0.08 to 2.5 mm ² , fine-wire, tension spring Ex i: 0.2 to 1.5 mm ² , fine-wire, push-in
Pneumatic connections	2 x hoses, 4 mm dia.
Pressure measurement range	0 to 25 mbar (standard) or 0 to 300 mbar (on request)
Pre-purge time	0 to 120 min
Weight	5.8 kg

The SILAS^{pz} Ex p control unit controls and monitors the pre-purge and operating phase of pressurised enclosure equipment protected in accordance with ignition protection type pz. Digital or proportional purge gas valves can be used as purge gas valves. The parameters can be set using the integrated WEB interface or the optionally available p operator panel. The SILAS^{pz} features two release relays; one which is energised and one which has floating contacts. Two signal relays with one changeover contact each are additionally available. Three PT100/1000 inputs are available to monitor the temperature of the Ex p-protected equipment. Up to three switch values can be assigned to them. Model II comes complete with integrated pressure measurement. The following components are additionally required to set up a complete control system:

- Pressure monitor
- Purge gas valve, proportional or digital
- Valve fuse
- Pressure reducer
- There is the option to connect a p operator panel

Electrical data

Supply voltage	24 V DC to 44 V DC, ±10 % or 100 V AC to 230 V AC, ±10 %
Power consumption	Pv = approx. 19 watts
Normally open contacts	K1 release, max. 5 A (AC1) K2 release, floating, max. 230 V AC/3 A (AC1) K3 and K4 signal relays, floating, changeover contact, max. 1 A (AC1)
Inputs	3 x PT100/1000 1 x bypass 1 x main switch

Dimensions

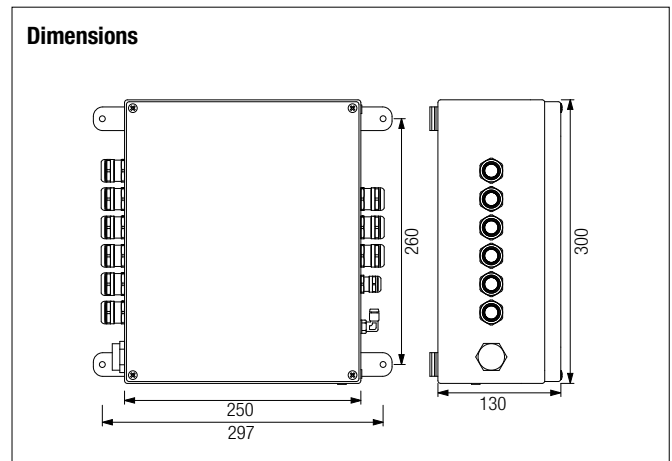

Ordering information

	Code no.
24 V DC to 44 V DC, ±10 %	1
100 V AC to 230 V AC, ±10 %	2

Complete order no. A7-37S2-2111/ 520

Please insert code number.

The accessories and order information can be found on the accessory pages. Technical data subject to change without notice.